

GunVault.
THE ORIGINAL. SINCE 1990

MultiVault®

GV2000S | GV2000D | GVB2000

FASTER. SAFE. TOUGH.



GunVault

The Leaders in Responsible Firearm Storage

Since 1990, **GunVault** has been an industry leader and innovator of quick access personal safes. We pride ourselves on our commitment to manufacture a responsible firearm storage solutions with the highest in quality and patented design. At **GunVault** we understand that in a time of crisis you rely on the security and protection GunVault provides.

Thank you for your trust and welcome to the **GunVault** family.

Index

»» Quick Start Guide	4
Battery Installation	
Programming	
Digital Unit	
Biometric Unit	
Additional Users	5
Opening Safe with Biometric Scanner	
»» Product Features	6
Standard	
Deluxe	
Biometric	
»» Safety Features Section	7
Tamper Detection	
Low Battery Warning Indicator	
Security Sleep Mode	
Audio Control	
»» Added Features Section	7
Motion Detection Alarm	
Setting Sensitivity for Motion Detection Alarm	
AC/DC Power Adapter	8
Interior Light	
Mounting Your MiniVault	
»» Warnings	10
»» GunVault Exclusive 5 Year Warranty	11
»» Warranty Registration	12

Quick Start Guide

»» Battery Installation

The lock manufacturer highly recommends using either a Duracell or Energizer 9V alkaline battery with an expiration date of 5 years into the future.

When installing or replacing the battery, always hold the battery connection cap while disconnecting or attaching the 9volt battery. Do not pull on the cables as this could cause the power supply to malfunction.

Step 1: Use the backup keys to unlock the unit.

Step 2: Reach inside the unit and carefully pull the interior foam roof back to front until the battery holder is exposed. Do not detach the interior foam completely from the unit.

Step 3: Connect the recommended 9V battery to the power cable inside the unit. When the battery is connected you will hear a single beep indicating the unit has power.

Step 4: After the battery is connected to the power cable, carefully press the battery into the holder for a secure fit. Push the foam roof back into place.

Programming

»» Digital Unit

Step 1: Open the unit with the backup key provided or by using the factory default code. The default code is a single sequential press of each button from left to right.

Step 2: Press and hold the Learn button located inside the unit. A beep will sound, and the light will turn green and remain illuminated. This light indicates the lock is ready to be programmed.

Step 3: The indicator light will remain activated as you enter the new access code. The code can be a minimum of three entries or maximum of six entries.

Step 4: Press and hold the Learn button a second time until the safe beeps, and the indicator light turns red and remains illuminated. Re-enter the new access code.

Step 5: Press and hold the Learn button one last time until the indicator light flashes green and beeps five times. If the indicator light flashes red and beeps five times, an error has occurred and you will need to repeat steps 2-5.

Step 6: Test your new code and repeat steps 2-5 if necessary.

Step 7: Your unit is programmed and ready to use.

»» Biometric Unit

New units are set in DEMO mode, meaning the unit can be opened without a fingerprint.

Step 1: Open the unit by pressing the START button, which is located to the right of the biometric scanner.

Step 2: Press and hold the START button again while the indicator light is flashing. The light will stay on and the scanner will illuminate. Once the scanner is active, you will need to release the START button.

Step 3: Place your finger over the scanner. Press and release the START button until the indicator light turns green and beeps twice, which indicates a successful fingerprint enrollment. If the unit flashes red, repeat steps 2 and 3.

Step 4: Test your unit to ensure that your fingerprint was enrolled successfully.

Step 5: Repeat all steps to add up to 20 fingerprints.

»» Programming Additional Users

Leave the unit door open while you program your safe.

Step 1: Open the unit using the biometric scanner.

Step 2: While the indicator light is flashing, press and hold the START button.

Step 3: With the optical scanner now illuminated, place a new fingerprint on the scanner. Press and release the START button. Hold your finger on the optical scanner until you hear one long beep and the light flashes green. This indicates the fingerprint was successfully enrolled.

Step 4: Repeat steps 2 and 3 for additional fingerprints.

»» Opening the Safe Using the Biometric Scanner

Step 1: Press the START button.

Step 2: Using a previously enrolled fingerprint, place your finger on top of the scanner.

Step 3: The indicator light will flash green and beep twice when the fingerprint is accepted. The safe will then open.

Note: If the light flashes green and then red, your fingerprint was not accepted, and you will need to try again.

»» Resetting the Unit

Individual users cannot be deleted from the unit. All users must be deleted in order to remove any one fingerprint or the unit must be reset.

Step 1: Open the unit using a fingerprint or the keys that were provided. Locate the DELETE button in the interior roof to the left of the battery compartment.

Step 2: Press and hold the DELETE button.

Step 3: While pressing the DELETE button, press the START button to activate the unit.

Step 4: Continue to hold the DELETE button until the indicator light stops flashing. Once the light has stopped, you can release the DELETE button.

Step 5: All fingerprints have been deleted. Follow the steps under Programming to reprogram your unit.

Product Features

(MultiVault Standard | MultiVault Deluxe)

1. AC/DC Power Jack
(Deluxe model only)
2. Keypoint
3. Digital Keypad
4. Interior Shelf
5. Delete Button
6. Battery Holder
(Inside the unit)
7. Indicator Light
8. Mounting Holes
(2) Key-slot holes
(4) Round holes
9. Internal Courtesy Light
(Deluxe model only)
10. Learn Button
(Located on the inside top panel of the unit)
11. AC/DC Power Supply Cable
(Deluxe model only)
12. Backup Keys

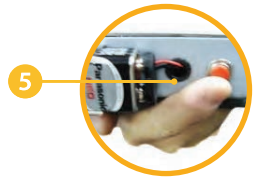
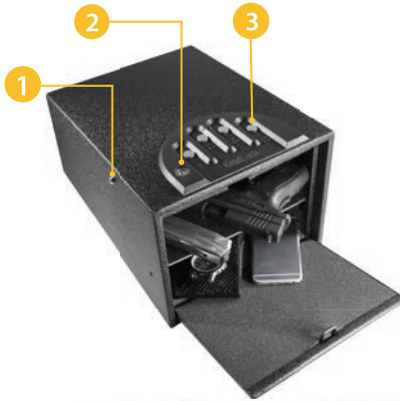

Product Features

(Biometric MultiVault)

1. Keypoint
2. Biometric Optical Scanner
3. Start Button
4. Indicator Light
5. Interior Shelf
6. Delete Button
7. Battery Holder
(Located on the inside top panel of the unit)
8. AC/DC Power Jack
(Deluxe model only)
9. Mounting Holes
(2) Key-slot holes
(4) Round holes
10. Internal Courtesy Light
11. AC/DC Power Supply Cable
12. Backup Keys

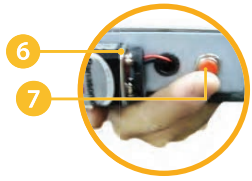
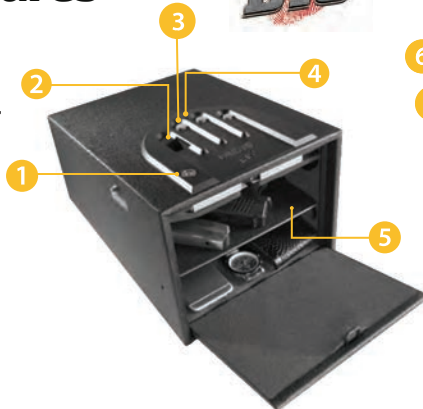

Safety Feature Section for Digital Units

»» Tamper Detection

Entering an invalid access code triggers the Tamper Detection feature.

Step 1: Press and hold buttons 2 and 3 for five seconds to initiate the Tamper Detection indicator.

Step 2: If tampering has been detected, the indicator light will remain red until buttons 2 and 3 are released.

Step 3: If tampering was not detected, the indicator light will remain green until buttons 2 and 3 are released.

»» Low Battery Warning Indicator

When your unit has a low battery, the unit indicator light will flash red and beep six times. If the battery is too low, the light will start flashing red and beep continuously until the battery is replaced. If the battery is completely depleted you will only hear a light hum from the unit.

Replace your battery following the steps in the Battery Installation section.

»» Security Sleep Mode

After six incorrect entries the Security Sleep Mode feature will activate and lockout any new keypad entries for 2 minutes.

To verify that the Security Sleep Mode is deactivated, wait 2 minutes and then test your unit by slowly entering your combination.

If you have forgotten or lost your combination, please follow the instructions in the section labeled Programming Digital Keypad.

»» Audio Control

This feature turns unit's audio on and off.

Step 1: Open the unit and locate the Mute button on the front interior panel of the unit.

Step 2: Press and hold the Mute button for three (3) seconds. The indicator light will remain red and produce one audible beep while the Mute button is compressed. When the indicator light flashes green three times, with no beep, you have successfully activated the mute audio control feature. When the same steps are followed and the indicator light flashes green and beeps three times, you have successfully deactivated the mute audio control feature.

Added Features for Deluxe and Biometric Units

»» Motion Detection Alarm

The Motion Detection Alarm activates when the unit is moved or disturbed. To enable this feature, follow the steps below.

Step 1: Press and hold buttons 1 and 4 simultaneously for 5 seconds.

Step 2: The unit will beep continuously for 10 seconds, indicating that the Motion Detection Alarm is active.

»» Setting the Sensitivity Level for the Motion Detection Alarm

The Motion Detection Alarm has four levels of sensitivity. Level 1 is most sensitive, and level 4 is least sensitive. The factory default is level 2.

Step 1: Press and hold the LEARN button for 2 seconds. The indicator light will flash green and beep.

Step 2: Press and hold the LEARN button again and wait for the green light and beep.

Step 3: Press the appropriate button on the keypad for the desired sensitivity level. To set the unit at max sensitivity, press the button closest to the indicator light.

»» AC/DC Power Adapter for External Power Source

The external power supply is not a battery charger and is only intended for use when the batteries are installed.

When the unit's battery is low, the external AC/DC power supply will power the unit while you replace the battery.

Step 1: Insert the external AC/DC power supply cable into the power jack located on the side of the unit.

Step 2: Replace the battery using the recommended 9V alkaline battery.

Step 3: Once the battery has been replaced, remove the external power supply cable from the unit.

»» Interior Light

The interior light activates for five seconds when the safe door is opened. The light will illuminate the contents of your safe, thus making it easier to access in the dark.

»» Mounting Your MiniVault

Warning: Mounting this GunVault with the door facing down will cause the contents to fall out when opened.

Step 1: Using the paper template provided drill starter holes into the desired mounting surface.

Step 2: Fasten the screws through the keyhole slots in the paper template. Be sure to leave room between the head of the screw and the mounting surface.

Step 3: Glide the mounting keyhole slots on the unit over the screws.

Step 4: Lift the interior foam padding on the bottom of the unit and insert screws into the remaining holes. A minimum of 3 screws must be used to mount the safe.

Step 5: Once all screws have been fastened, smooth the interior foam into place.



Safes, Accesories and More!

Loving your new GunVault safe and want to purchase more?

Check out our website www.GunVault.com for special promotions, product information and more.

»» SAFE CATEGORIES »» ACCESSORIES »» VITAL INFORMATION

- Digital Safes
- Biometric Safes
- AR Safes
- Security cable
- MagVault
- Downloadable manuals
- How-to video tutorials
- Warranty registration
- Frequently Asked Questions
- and MORE

VISIT OUR WEBSITE FOR FAQ'S, VIDEO TUTORIALS AND MORE.

Safety Warnings

- Always keep your safe closed and locked when not in use.
- Children should not play with, around or in any safe at any time.
- Keep backup keys and access code combinations in a secure place away from children.
- Keep the included high-strength steel security cable in a secure place away from children.
- This safe or any other firearm storage device cannot take the place of other safety procedures, including advising children of the dangers of firearms.
- Keep a record of your key number and serial number in a secure place separate from your safe.
- To enjoy the maximum-security benefits of this safe, it must be mounted in place. Use of this product as a storage receptacle without mounting may compromise security of the safe.
- Do not mount any GunVault product with the door facing down. The contents may fall out when the door is opened.

⚠ WARNING: This product can expose you to chemicals including Di(2-ethylhexyl)phthalate (DEHP) which is known to the State of California to cause cancer and birth defects or other reproductive harm. For more information go to [P65Warnings.ca.gov](https://www.P65Warnings.ca.gov)

Important Notices

- The backup key is for emergency use only in the event of fingerprint failure or forgotten passcode. For replacement keys, visit [GunVault.com/key-replacement-form/](https://www.GunVault.com/key-replacement-form/) to complete the online key replacement form. To receive a replacement key, you will need to know the key number associated with your unit. You can find this information on the unit engraved on the key port.
- The manufacturer recommends that you lightly coat the door hinge spring and door latch-loop with quality oil at least once a year. Never spray anything into the latch mechanism as it can damage the safe.
- Do not try to remove the key while in the turned position. This may damage the unit or key.

Firearm Safety

The manufacturer of this product does not recommend, suggest, advise, promote, or otherwise condone the ownership or use of firearms. We at GunVault believe the decision to own or use a firearm is a serious decision that should only be made by an adult who has carefully considered the risks and benefits of such a decision. GunVault recommends that you obtain as much information as possible on firearm safety. Always handle firearms as if they are loaded and ready to fire. Never drink alcohol or use drugs while operating this safe or any firearm. Never grab your firearm by the trigger when removing or placing in to safe. Always keep your firearm safety mechanism engaged while stored inside the safe. Always follow the firearm safety rules set out by the firearm's manufacturer.

GunVault Exclusive 5 Year Warranty

1. GunVault (the "Company") warrants to the original consumer (the "Purchaser") of any GunVault safe (the "GunVault safe") purchased after January 1, 2014 against any damage caused by fire, burglary or attempted burglary for a period of five (5) years from the date of purchase.
2. The Company warrants to the purchaser that the GunVault safe will be free from defects in workmanship and materials for a period of one (1) year from the date of purchase.
3. These warranties are not assignable or transferable to any other person.
4. Any damage to the GunVault safe as a result of misuse, tampering, abuse, neglect, accident, improper installation, modification, unauthorized service, destruction, or the alteration of the serial number, or use in violation of the instructions furnished by the Company will void this warranty.
5. The sole responsibility of the Company shall be limited to the repair or replacement (in its sole discretion) of any component of the GunVault safe which fails to conform to this warranty at no cost to the purchaser for the period of the warranty.
6. Contact the Company directly to obtain service under this warranty. If it becomes applicable to send a defective product to the Company, a Return Authorization Number must first be obtained from the company. In order to obtain service under this warranty, purchaser must provide the Company with the following items (a) proof of purchase, (b) police or fire department report, (c) photographs of damaged safe, and (d) written testimonial.
7. Products shipped without prior Return Authorization and Return Authorization Number may not be accepted, and the Company will not be responsible for their disposition and/or cost of return to the owner.
8. The Company will not assume any responsibility for any loss or damage incurred in shipping. All return authorized products should include a copy of the original invoice in order for this warranty to be honored.
9. This warranty is not an insurance policy. The Company is not responsible for any manner of damage to or theft of the Purchaser's GunVault safe or its contents.
10. We recommend that the warranty registration be completed online in order to validate this warranty.
11. Any implied warranties that the purchaser may have are limited to the duration of the warranties described above. There are no further warranties that extend or apply beyond the face hereof, and the company expressly disclaims and excludes any and all warranties of merchant ability or fitness for a particular purpose. Some states do not allow limitations on how long an implied warranty lasts, so the above limitation may not apply to you.
12. Repair or replacement shall be the sole remedy for the purchaser under this warranty. The company shall not be liable for any direct, indirect, incidental or consequential damages, losses or expense arising from the use or misuse of the GunVault safe. Some states do not allow the exclusion or limitations of incidental or consequential damages, so the limitation may not apply to you.
13. This warranty gives you specific legal rights and you may also have other rights which vary from state to state.
14. This warranty is only valid in the United States. If outside of the U.S. we encourage you to contact your point of purchase for further warranty help.



Please visit GunVault.com for Replacement Promise details*

GUNVAULT PRODUCT REGISTRATION

To submit your warranty registration, go to www.GunVault.com/warranty or call our Customer Service Department at (847) 665-1626.

For key replacement visit the GunVault.com/key-replacement-form to complete the online key replacement form. In order to receive a replacement key you will need to know the key number associated with your unit. You can find this information on the unit engraved on the keyport.

**PLEASE FILL OUT THE SECTION BELOW AND STORE
IN A SAFE LOCATION OUTSIDE OF YOUR UNIT.**

THIS IS NOT A REGISTRATION FORM

Safe Model:

Purchased from:

Date of Purchase:

Serial Number:

(This number can be found inside unit)

Key Number:

SAFE QUICK STRONG SMART®



Customer Support Hours:

Monday - Friday 6:00 am - 4:00 pm (PST)

Excluding Holidays *Hours subject to change

(847) 665-1626

© 2021 CANNON SECURITY PRODUCTS

2895 W. Capovilla Avenue Suite 140

Las Vegas, Nevada 89119

GunVault.com